

LS2-NMNM-5M-D



D-CLASS LSF2-50 SureFlex® Jumper with interface types N Male and N Male, 5 m

Product Classification

Product Type	SureFlex® D-CLASS, dynamic PIM
Product Brand	HELIAX® SureFlex®
Product Series	LSF2-50

General Specifications

Body Style, Connector A	Straight
Body Style, Connector B	Straight
Interface, Connector A	N Male
Interface, Connector B	N Male
Interface Coupling Nut Flat, Connector A	18 mm 0.709 in
Interface Coupling Nut Flat, Connector B	18 mm 0.709 in
Specification Sheet Revision Level	A

Dimensions

Length	5 m 16.404 ft
Nominal Size	3/8 in

Logo Image

LS2-NMNM-5M-D



Electrical Specifications

3rd Order IMD Dynamic	-119 dBm
3rd Order IMD Dynamic Test Method	Two +43 dBm carriers per IEC 62037

VSWR/Return Loss

Frequency Band	VSWR	Return Loss (dB)
698–970 MHz	1.065	30
1700–2200 MHz	1.065	30
2200–2700 MHz	1.083	28
3400–3800 MHz	1.222	20
4000–6000 MHz	1.222	20

Jumper Assembly Sample Label

LS2-NMNM-5M-D



Environmental Specifications

Immersion Test Method

Meets IEC 60529:2001, IP68 in mated condition

Included Products

- LS2NM-S2 – N Male for 3/8 in LSF2-50 cable, factory attached
- LSF2-50 – LSF2-50, HELIAX® Superflexible Foam Coaxial Cable, corrugated copper, 3/8 in, black PE jacket (Not for Individual Sale - Jumpers only)

LS2NM-S2



N Male for 3/8 in LSF2-50 cable, factory attached

Product Classification

Product Type	Wireless and radiating connector
Product Brand	HELIAX®

General Specifications

Body Style	Straight
Cable Family	LSF2-50
Inner Contact Attachment Method	Solder
Inner Contact Plating	Silver
Interface	N Male
Outer Contact Attachment Method	Solder
Outer Contact Plating	Trimetal

Dimensions

Length	31.2 mm 1.228 in
Diameter	20.25 mm 0.797 in
Nominal Size	3/8 in

Outline Drawing

LS2NM-S2

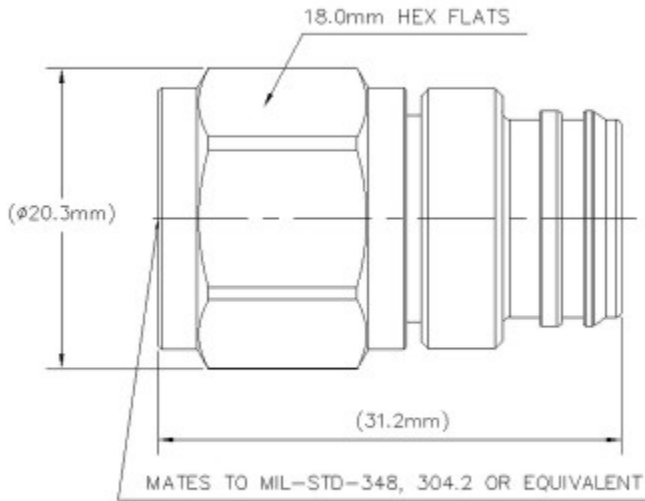

Electrical Specifications

3rd Order IMD at Frequency	-110 dBm @ 910 MHz
3rd Order IMD Test Method	Two +43 dBm carriers
Insertion Loss Coefficient, typical	0.05
Cable Impedance	50 ohm
Connector Impedance	50 ohm
dc Test Voltage	2500 V
Inner Contact Resistance, maximum	1 mOhm
Insulation Resistance, minimum	5000 MOhm
Operating Frequency Band	0 – 6000 MHz
Outer Contact Resistance, maximum	0.25 mOhm
Peak Power, maximum	10 kW

VSWR/Return Loss

Frequency Band	VSWR	Return Loss (dB)
0–3.8 GHz	1.025	38.17
3.8–6 GHz	1.046	32.96

Mechanical Specifications

LS2NM-S2

Connector Retention Tensile Force	200 N 44.962 lbf
Connector Retention Torque	2.7 N-m 23.897 in lb
Coupling Nut Proof Torque	1.7 N-m 15.046 in lb
Coupling Nut Retention Force	450 N 101.164 lbf
Interface Durability	500 cycles
Mechanical Shock Test Method	IEC 60068-2-27

Environmental Specifications

Operating Temperature	-55 °C to +85 °C (-67 °F to +185 °F)
Storage Temperature	-65 °C to +125 °C (-85 °F to +257 °F)
Corrosion Test Method	IEC 60068-2-11
Immersion Depth	1 m
Immersion Test Mating	Mated
Immersion Test Method	IEC 60529:2001, IP68
Moisture Resistance Test Method	IEC 60068-2-3
Thermal Shock Test Method	IEC 60068-2-14
Vibration Test Method	IEC 60068-2-6

Packaging and Weights

Weight, net	30.74 g 0.068 lb
--------------------	--------------------

Regulatory Compliance/Certifications

Agency	Classification
CHINA-ROHS	Below maximum concentration value
ROHS	Compliant
UK-ROHS	Compliant



* Footnotes

Insertion Loss Coefficient, typical	0.05√freq (GHz) (not applicable for elliptical waveguide)
Immersion Depth	Immersion at specified depth for 24 hours

LSF2-50



LSF2-50, HELIAX® Superflexible Foam Coaxial Cable, corrugated copper, 3/8 in, black PE jacket (Not for Individual Sale - Jumpers only)

Product Classification

Product Type	Coaxial wireless cable
Product Brand	HELIAX® SureFlex®
Product Series	LSF2-50 MLOC
Ordering Note	ANDREW® standard product (Global)

General Specifications

Flexibility	Superflexible
Jacket Color	Black
Performance Note	Attenuation values typical, guaranteed within 5%

Dimensions

Diameter Over Dielectric	7.645 mm 0.301 in
Diameter Over Jacket	11.024 mm 0.434 in
Inner Conductor OD	3.048 mm 0.12 in
Outer Conductor OD	9.906 mm 0.39 in
Nominal Size	3/8 in

Electrical Specifications

Cable Impedance	50 ohm ±1 ohm
Capacitance	80.7 pF/m 24.597 pF/ft
dc Resistance, Inner Conductor	3.65 ohms/km 1.113 ohms/kft
dc Resistance, Outer Conductor	4.64 ohms/km 1.414 ohms/kft
dc Test Voltage	2500 V
Inductance	0.202 µH/m 0.062 µH/ft
Insulation Resistance	100000 MOhms-km
Jacket Spark Test Voltage (rms)	5000 V
Operating Frequency Band	1 – 10200 MHz

LSF2-50

Peak Power 15.6 kW

Velocity 82 %

Attenuation

Frequency (MHz)	Attenuation (dB/100 m)	Attenuation (dB/100 ft)	Average Power (kW)
1.0	0.422	0.129	15.6
1.5	0.501	0.153	15.6
2.0	0.567	0.173	14.27
10.0	1.179	0.359	6.86
20.0	1.641	0.5	4.93
30.0	1.998	0.609	4.05
50.0	2.567	0.782	3.15
85.0	3.342	1.019	2.42
88.0	3.4	1.036	2.38
100.0	3.625	1.105	2.23
108.0	3.768	1.148	2.15
150.0	4.447	1.355	1.82
174.0	4.795	1.461	1.69
200.0	5.147	1.569	1.57
204.0	5.199	1.585	1.56
300.0	6.336	1.931	1.28
400.0	7.351	2.241	1.1
450.0	7.815	2.382	1.03
460.0	7.905	2.409	1.02
500.0	8.257	2.517	0.98
512.0	8.36	2.548	0.97
600.0	9.084	2.769	0.89
700.0	9.851	3.003	0.82
800.0	10.572	3.222	0.77
824.0	10.739	3.273	0.75
894.0	11.214	3.418	0.72
960.0	11.648	3.55	0.69
1000.0	11.904	3.628	0.68
1218.0	13.231	4.033	0.61
1250.0	13.417	4.089	0.6

LSF2-50

1500.0	14.806	4.512	0.55
1700.0	15.848	4.83	0.51
1794.0	16.32	4.974	0.5
1800.0	16.35	4.983	0.49
2000.0	17.321	5.279	0.47
2100.0	17.791	5.423	0.45
2200.0	18.253	5.563	0.44
2300.0	18.706	5.701	0.43
2500.0	19.589	5.97	0.41
2700.0	20.445	6.231	0.4
3000.0	21.682	6.608	0.37
3400.0	23.26	7.089	0.35
3600.0	24.022	7.321	0.34
3700.0	24.396	7.436	0.33
3800.0	24.767	7.549	0.33
3900.0	25.134	7.661	0.32
4000.0	25.498	7.771	0.32
4100.0	25.858	7.881	0.31
4200.0	26.215	7.99	0.31
4300.0	26.569	8.098	0.3
4400.0	26.92	8.205	0.3
4500.0	27.267	8.311	0.3
4600.0	27.612	8.416	0.29
4700.0	27.954	8.52	0.29
4800.0	28.294	8.623	0.29
4900.0	28.63	8.726	0.28
5000.0	28.965	8.828	0.28
6000.0	32.183	9.809	0.25
8000.0	38.096	11.611	0.21
8800.0	40.314	12.287	0.2
10000.0	43.516	13.263	0.19

Material Specifications

Dielectric Material	Foam PE
Jacket Material	PE

LSF2-50

Inner Conductor Material	Copper-clad aluminum wire
Outer Conductor Material	Corrugated copper

Mechanical Specifications

Minimum Bend Radius, multiple Bends	25.4 mm 1 in
Minimum Bend Radius, single Bend	25.4 mm 1 in
Number of Bends, minimum	15
Tensile Strength	118 kg 260.145 lb
Bending Moment	2.2 N-m 19.472 in lb
Flat Plate Crush Strength	2 kg/mm 111.995 lb/in

Environmental Specifications

Installation temperature	-40 °C to +60 °C (-40 °F to +140 °F)
Operating Temperature	-55 °C to +85 °C (-67 °F to +185 °F)
Storage Temperature	-70 °C to +85 °C (-94 °F to +185 °F)
Attenuation, Ambient Temperature	68 °F 20 °C
Average Power, Ambient Temperature	104 °F 40 °C
Average Power, Inner Conductor Temperature	212 °F 100 °C
EN50575 CPR Cable EuroClass Fire Performance	Fca

Packaging and Weights

Cable weight	0.11 kg/m 0.074 lb/ft
---------------------	-------------------------

Regulatory Compliance/Certifications

Agency	Classification
CENELEC	EN 50575 compliant, Declaration of Performance (DoP) available
ISO 9001:2015	Designed, manufactured and/or distributed under this quality management system

