

- 1.0 GENERAL NOTES
 1.1 ALL METRIC DIMENSIONS ARE IN BRACKETS [X. X]
 1.2 FOR PATENT INFO: <https://www.adwpat.com>
 2.0 DESIGN NOTES
 3.0 MANUFACTURING/SPECIAL REQUIREMENTS
 3.1 BUS BAR SHOWN IN VARIOUS MOUNTING CONFIGURATIONS
 3.2 TIGHTEN ALL BOLTS SNUG TIGHT, DEFINED AS THE CONDITION OBTAINED WITH THE FULL EFFORT OF AN ASSEMBLER USING AN ORDINARY SPUD WRENCH TO BRING THE CONNECTING SURFACES INTO FIRM CONTACT
 4.0 TEST
 5.0 PACKAGING
 5.1 PACKAGING SHALL MEET ANDREW REQUIREMENTS PER DOCUMENT IS-PL-3005
 5.2 PRINTED DOCUMENT TO BE PLACED INSIDE POLYBAG AND THEN IN SHIPPING CONTAINER
 5.3 EXTRA HARDWARE MAY BE SUPPLIED, BAGGED AND SHIPPED

REVISIONS			
REV.	DESCRIPTION	DATE	APPROVED
A	INITIAL RELEASE	HC 25FEB14	TP
B	UPDATED DRAWING FORMAT; GB0316-4 (ITEM 8) WAS SB0316#4 PER SAP BOM	YC1059 10OCT25	BA1025 50105304AMO

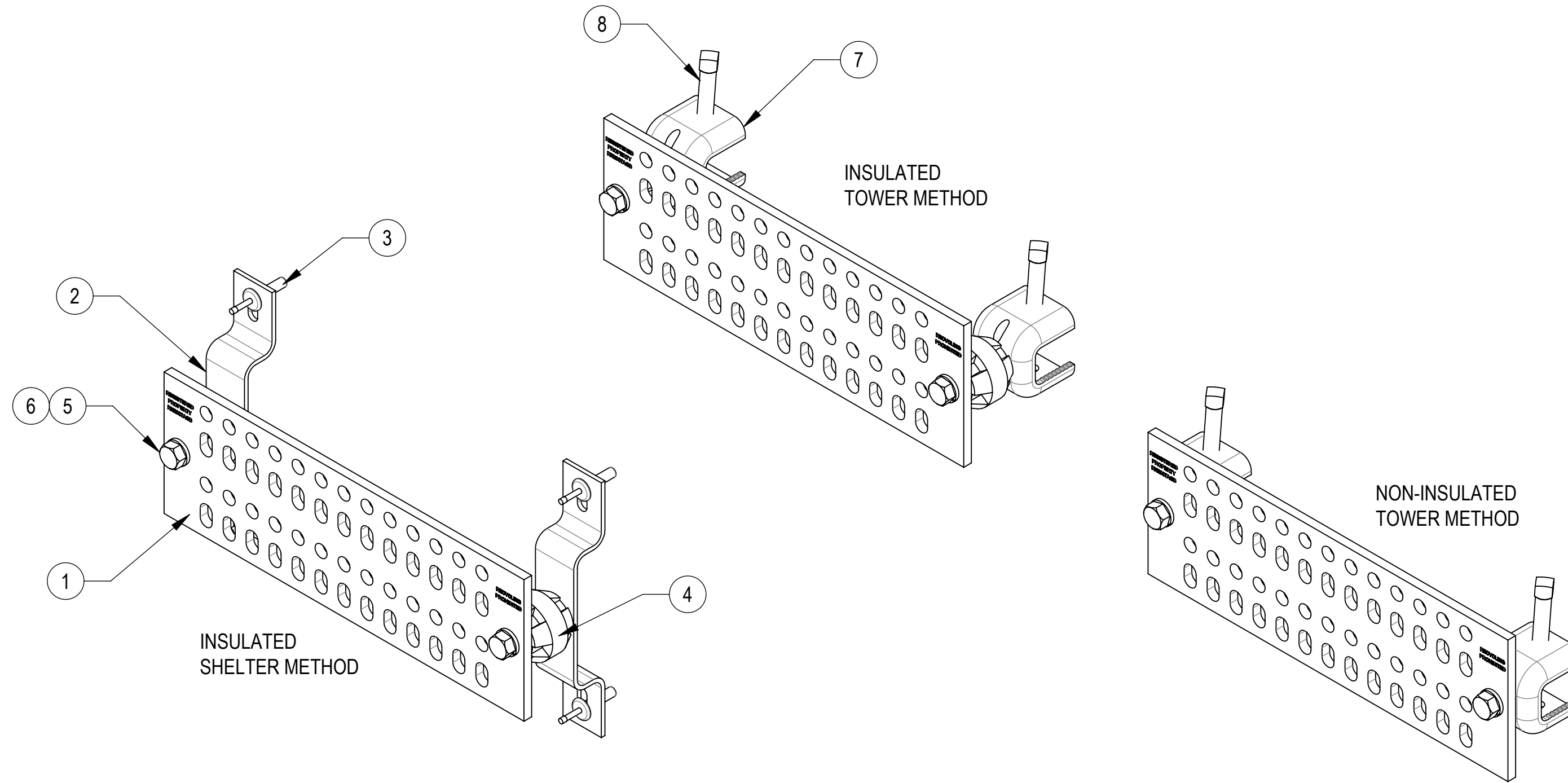

COMPONENT PART NUMBERS PROVIDED FOR ASSEMBLY PURPOSES;
 INDIVIDUAL COMPONENTS MAY BE SHIPPED AS PARTS WITHIN AN INCLUDED KIT.

ITEM NO.	PART NUMBER	DESCRIPTION	QTY.	WEIGHT	NOTE NO.
1	CBB0412M01T	GROUND BUSS BAR 4 X12 TINNED	1	3.05 LBS	
2	MT500GDP	STANDOFF BRACKET	2	0.33 LBS	
3	DPA141ZP	6.5 X 25mm DRIVE PIN ANCHOR	4	0.02 LBS	
4	MT520	INSULATOR W/ 3/8" INSERT	2	0.21 LBS	
5	SB0305	3/8" X 5/8" SS BOLT	4	0.04 LBS	
6	SWL-03	3/8" SS LOCK WASHER	4	0.01 LBS	
7	45840G-1	HANGER CLAMP	2	0.38 LBS	
8	GB0316-4	SQUARE HEAD SET SCREW, 3/8-16X1-3/4	2	0.07 LBS	

DENSITY		lbs/in ³
MASS	5.24	lbs
VOLUME	23.51	in ³
SURFACE AREA	259.54	in ²
HEIGHT		
LENGTH		
WIDTH		

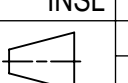

ANDREW® an Amphenol company

TOLERANCES		SAP MATERIAL MASTER	
1 PLACE .X[X] ± 0.12[3.0]	3 PLACE .XXX[X] ± 0.030[0.8]	CBB-0412T-1MU	
2 PLACE .XX[X] ± 0.06[1.5]	ANGLES ± 2°		
FINISH		MATERIAL	
UNLESS OTHERWISE SPECIFIED DIMENSIONS ARE IN INCHES INTERPRET PER ANSI Y 14.5M-1994	NAME	DATE	TITLE
	CE HC	25FEB14	GROUND BUS BAR KIT, TIN 4X12
	RW YC1059	10/10/2025	
	AD YMENG	10/13/2025	
	RE YMENG	10/14/2025	
ECN 50105304AMO			
SCALE	DOCUMENT NO.		
1:2	CBB-0412T-1MU		
SIZE	Auth Group	INSL	MODEL
C			VERSION STATUS REVISION
			01 RE B
		DRAWING	
		VERSION STATUS REVISION	01 RE B
			SHEET 1 OF 1

Confidential