

- 1.0 GENERAL NOTES  
 1.1 ALL METRIC DIMENSIONS ARE IN BRACKETS [X.X]  
 1.2 FOR PATENT INFO: <https://www.adwpat.com>
- 2.0 DESIGN NOTES
- 3.0 MANUFACTURING/SPECIAL REQUIREMENTS  
 3.1 TIGHTEN ALL BOLTS 3/8" OR LARGER SECURING FLAT PLATES SNUG TIGHT.  
 3.2 SNUG TIGHT IS DEFINED AS THE CONDITION OBTAINED WITH A FEW IMPACTS OF AN IMPACT WRENCH OR THE FULL EFFORT OF AN INSTALLER USING AN ORDINARY SPUD WRENCH TO BRING THE CONNECTED LAYERS (PLIES) OF STEEL INTO FULL CONTACT.  
 3.3 FOR BOLTS IN A PATTERN, TIGHTEN IN A CRISS-CROSS OR STAR SEQUENCE, INCREASING TORQUE IN GRADUAL STEPS UNTIL SNUG TIGHT.
- 4.0 TEST
- 5.0 PACKAGING  
 5.1 PACKAGING SHALL MEET ANDREW REQUIREMENTS PER DOCUMENT IS-PL-3005  
 5.2 PRINTED DOCUMENT TO BE PLACED INSIDE POLYBAG AND THEN IN SHIPPING CONTAINER  
 5.3 EXTRA HARDWARE MAY BE SUPPLIED, BAGGED AND SHIPPED

REVISIONS			
REV.	DESCRIPTION	DATE	APPROVED
A	INITIAL RELEASE	RDLS 13JUL18	
B	ADDED VIEWS TO HELP ASSEMBLY	MRC 19NOV18	
C	ADDED NEW PARTS, SCREWS, AND UPDATED NOTES	MRC 18DEC18	
D	CORRECTED MASS CALCULATION	ES1081 29MAR19	RW1048
E	UPDATED DRAWING FORMAT TO NEW	LL1090 05DEC25	BA1025 50106106AMO

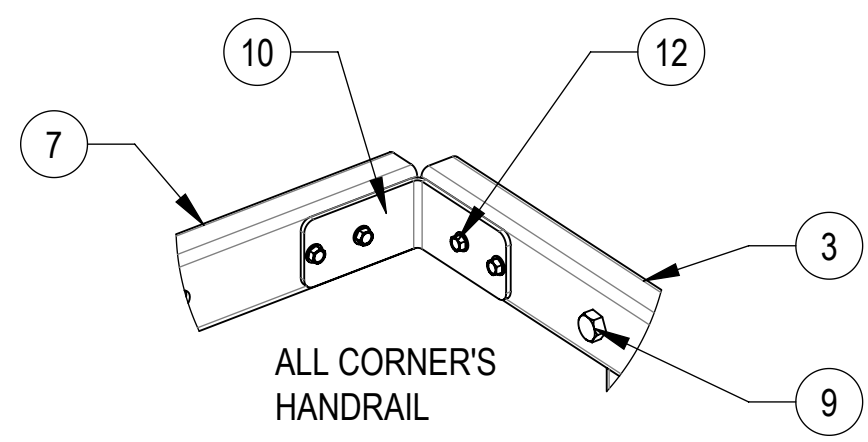

ALL CORNER'S  
HANDRAIL  
**DETAIL A**  
SCALE 1 : 4

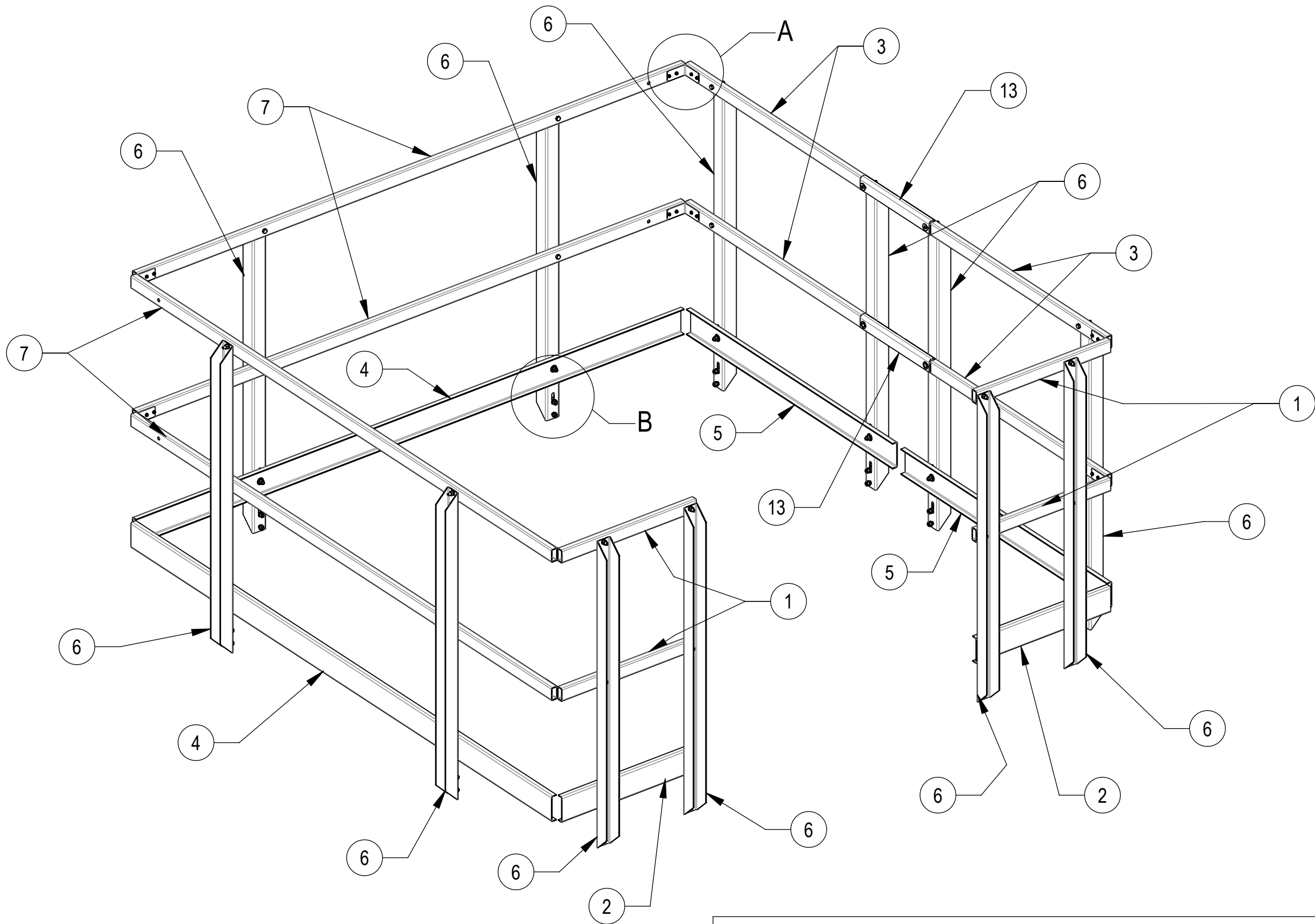
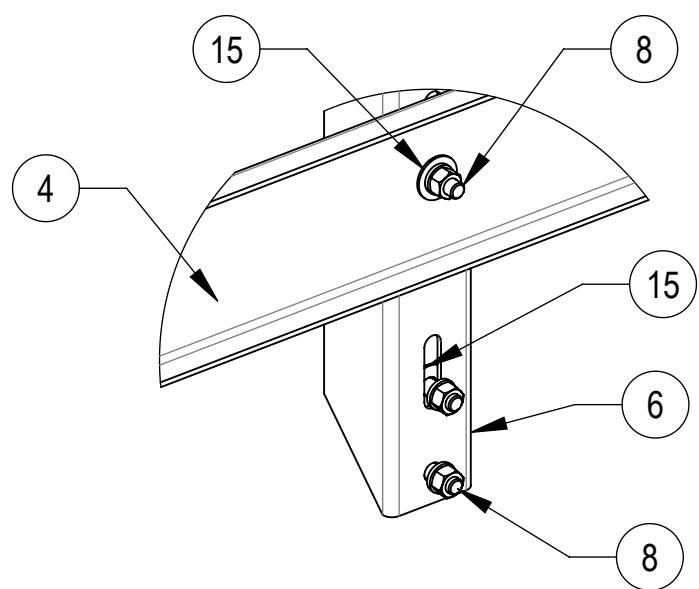

**DETAIL B**  
SCALE 1 : 4

COMPONENT PART NUMBERS PROVIDED FOR ASSEMBLY PURPOSES;  
 INDIVIDUAL COMPONENTS MAY BE SHIPPED AS PARTS WITHIN AN INCLUDED KIT.

ITEM	PART NO.	DESCRIPTION	QTY.	WEIGHT	NOTE NO.
1	MTC4037HR12	HANDRAIL, HORIZONTAL, 23"	4	4.10 LBS	
2	MTC4037HR13	PLATE, HANDRAIL TOEBOARD	2	4.04 LBS	
3	MTC4037HR14	HANDRAIL, HORIZONTAL, 46"	4	8.22 LBS	
4	MTC4037HR15	PLATE, HANDRAIL TOEBOARD	2	16.58 LBS	
5	MTC4037HR16	PLATE, HANDRAIL TOEBOARD	2	8.11 LBS	
6	MTC403721	POST, HANDRAIL	12	9.98 LBS	
7	MTC40378816	HANDRAIL, HORIZONTAL, 94"	4	16.79 LBS	
8	GB-03105	3/8" X 1" GALV BOLT KIT	36	0.05 LBS	
9	GB-03205	3/8" X 2" GALV BOLT KIT	24	0.08 LBS	
10	MTC3979HR19	ANGLE BRKT, HANDRAIL	8	0.32 LBS	
11	MTC9410WFW	5/16" GALV, WIDE FLAT WASHER 7/8" OD	6	0.01 LBS	
12	TS1288	12-24 X 7/8" SELF DRILLING SCREW	32	0.01LBS	
13	MTC4037HR21	FORMED ANGLE, HANDRAIL STIFFENER	2	2.08 LBS	
14	TS1220	12-24 X 2" SELF DRILLING SCREW	12	0.03 LBS	
15	GWF-03	3/8" GALV FLAT WASHER	28	0.01 LBS	



**ANDREW**® an Amphenol company

TOLERANCES		SAP MATERIAL MASTER	
0 PLACE X[X] ± .25[6.3]	2 PLACE .XX[X] ± 0.06[1.5]	<b>MTC4037HR</b>	
1 PLACE .X[X] ± 0.12[3.0]	ANGLES ± 2°		
FINISH		MATERIAL	
<small>UNLESS OTHERWISE SPECIFIED DIMENSIONS ARE IN INCHES INTERPRET PER ANSI Y 14.5M-1994</small>		NAME	DATE
		CE MRC	06/26/18
		RW LL1090	12/09/2025
		AD YMENG	12/12/2025
TITLE		<b>8x8 PLATFORM HANDRAIL W TOE BOARD</b>	
RE YMENG	12/12/2025		
ECN 50106106AMO		SCALE	DOCUMENT NO.
		<b>1:12</b>	<b>MTC4037HR</b>
SIZE	Auth Group	INSL	MODEL
<b>C</b>			
DENSITY		lbs/in³	
MASS		306.32 lbs	
VOLUME		1086.90 in³	
SURFACE AREA		18376.62 in²	
HEIGHT		49"	
LENGTH		96"	
WIDTH		96"	
VERSION		STATUS	
07		RE	
REVISION		VERSION	
F		05	
DRAWING		STATUS	
RE		E	
SHEET		1 OF 6	

Confidential

4

3

2

1

D

D

C

C

B

B

A

A

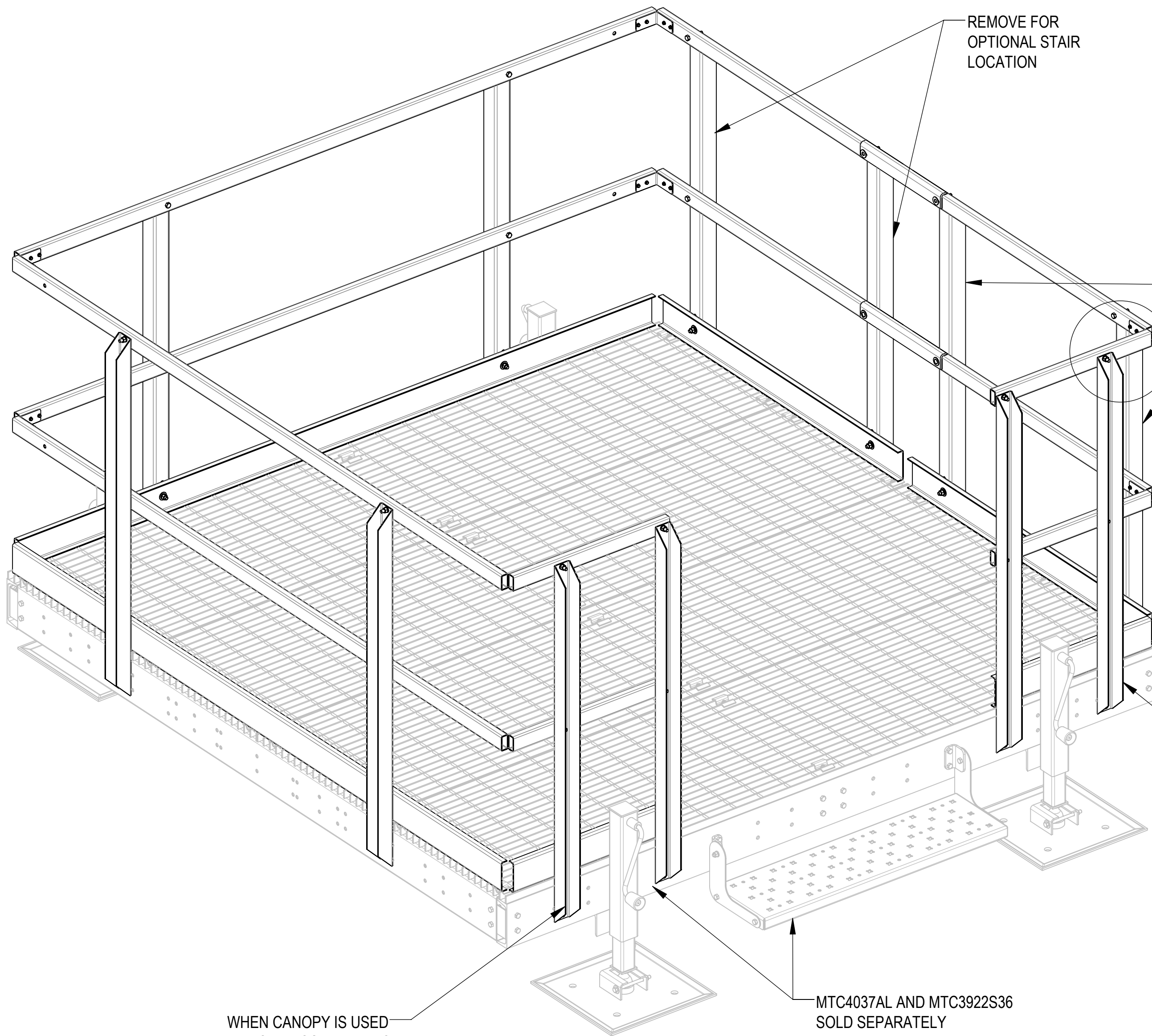

REMOVE FOR  
OPTIONAL STAIR  
LOCATION

REMOVE FOR  
OPTIONAL STAIR  
LOCATION

E

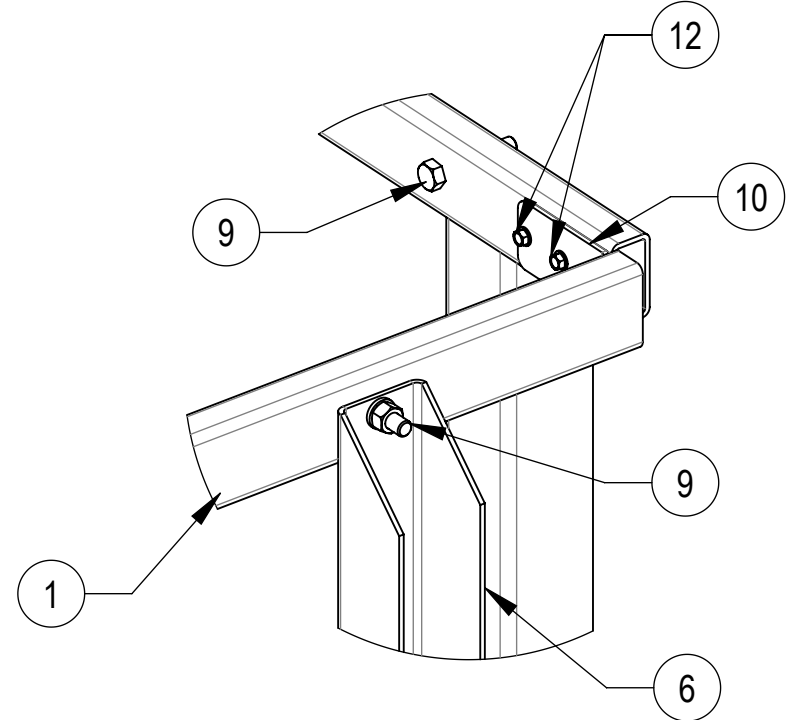

**DETAIL E**  
SCALE 1:4

WHEN CANOPY IS USED  
REMOVE POST AND TECH  
SCREW HANDRAIL INTO 4"  
CANOPY POST WITH TWO  
TS1220 SCREWS PER POST

MTC4037AL AND MTC3922S36  
SOLD SEPARATELY

WHEN CANOPY IS USED  
REMOVE POST AND TECH  
SCREW HANDRAIL INTO 4"  
CANOPY POST WITH TWO  
TS1220 SCREWS PER POST



TITLE  
8x8 PLATFORM HANDRAIL W TOE BOARD

SIZE <b>C</b>	SCALE <b>1:10</b>	DOCUMENT NO. MTC4037HR		
		DRAWING		SHEET 2 OF 6
		VERSION 05	STATUS RE	

Confidential

4

3

2

1

4

3

2

1

D

D

C

C

B

B

A

A

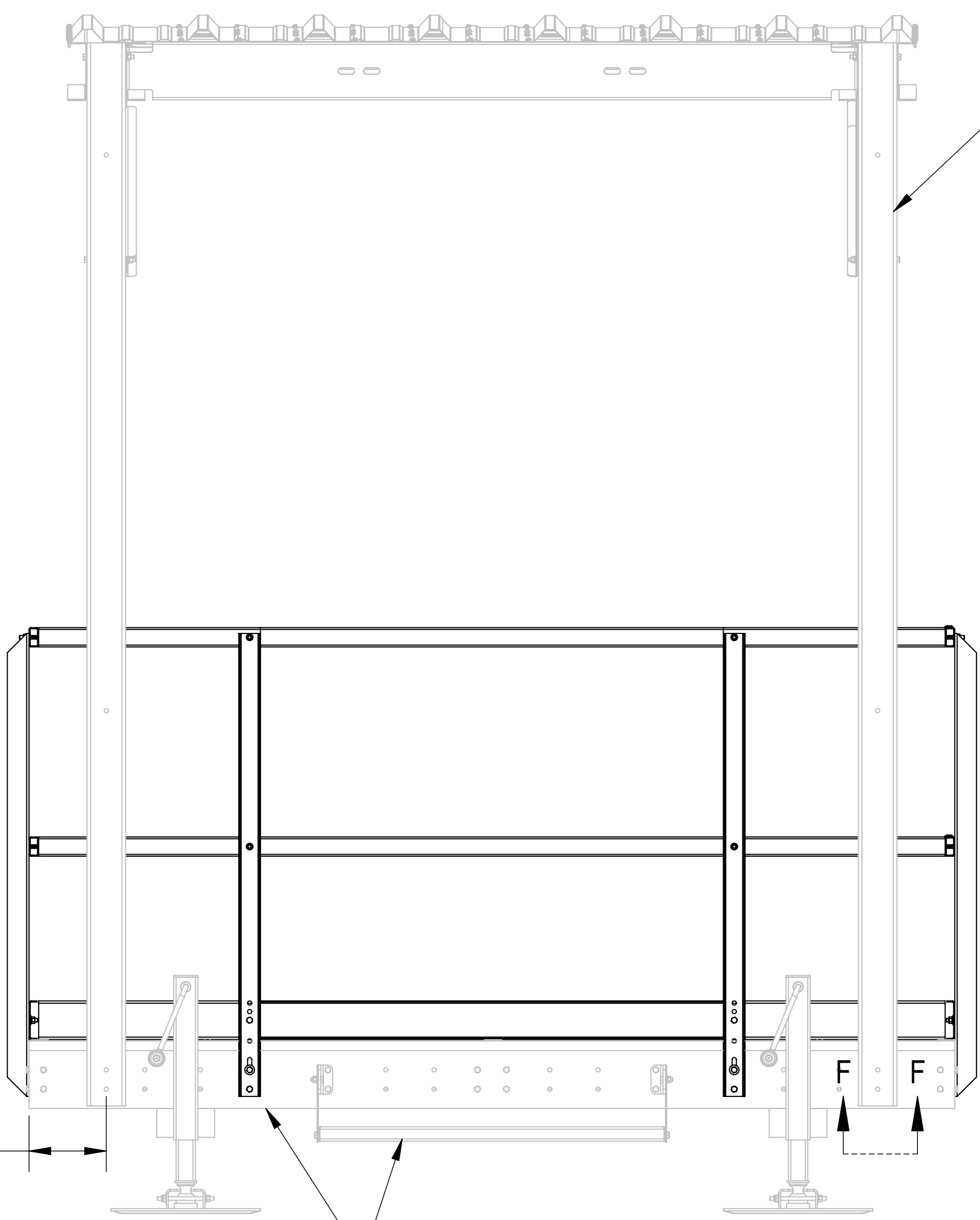

MTC4037CR  
SOLD SEPARATELY

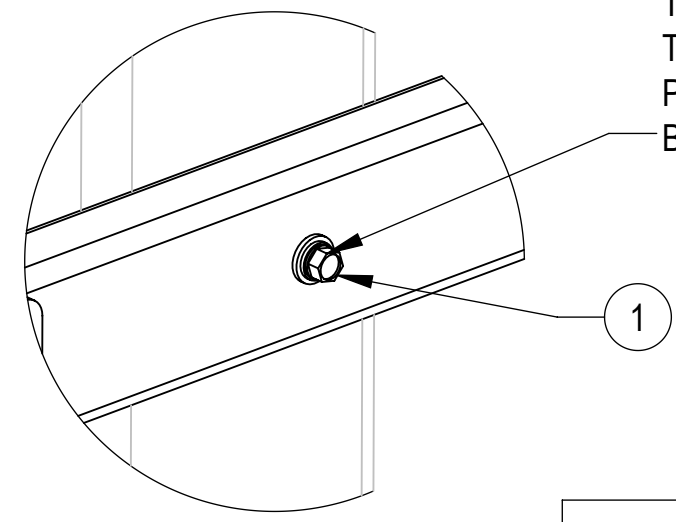
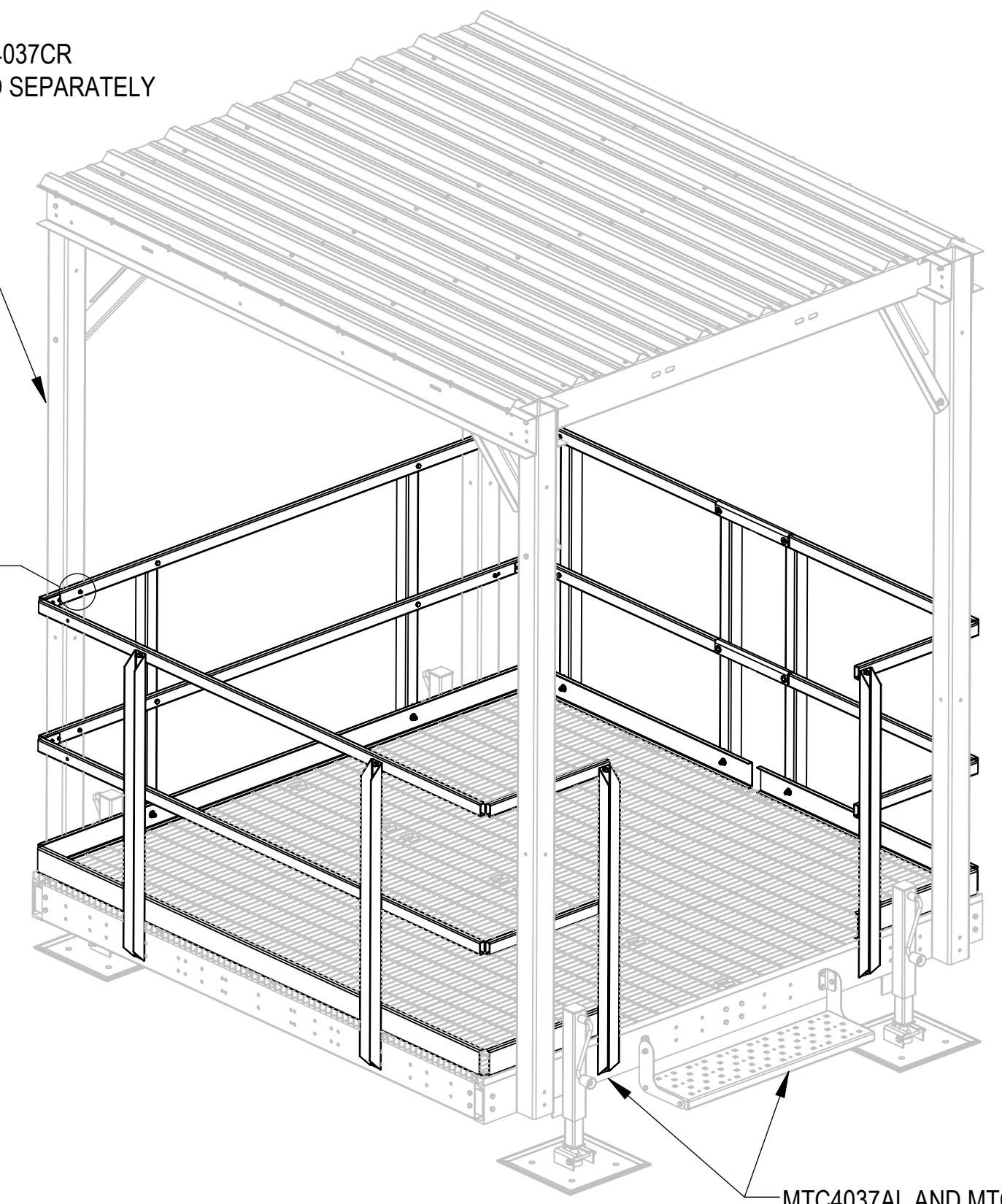

**DETAIL H**  
SCALE 1 : 2

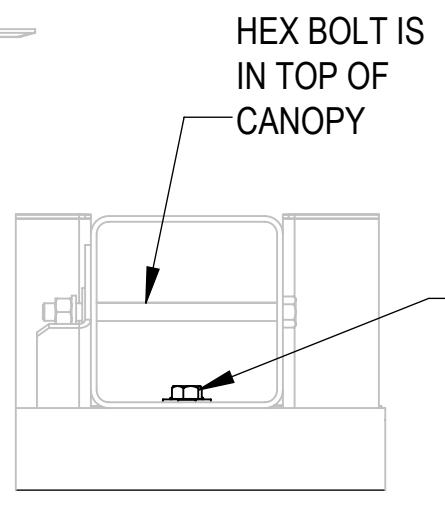

**SECTION F-F**  
SCALE 1 : 4



TITLE  
**8x8 PLATFORM HANDRAIL W TOE BOARD**

SIZE <b>C</b>	SCALE <b>1:12</b>	DOCUMENT NO. <b>MTC4037HR</b>
------------------	----------------------	----------------------------------

	DRAWING			SHEET 3 OF 6
	VERSION 05	STATUS RE	REVISION E	

Confidential

4

3

2

1

4

3

2

1

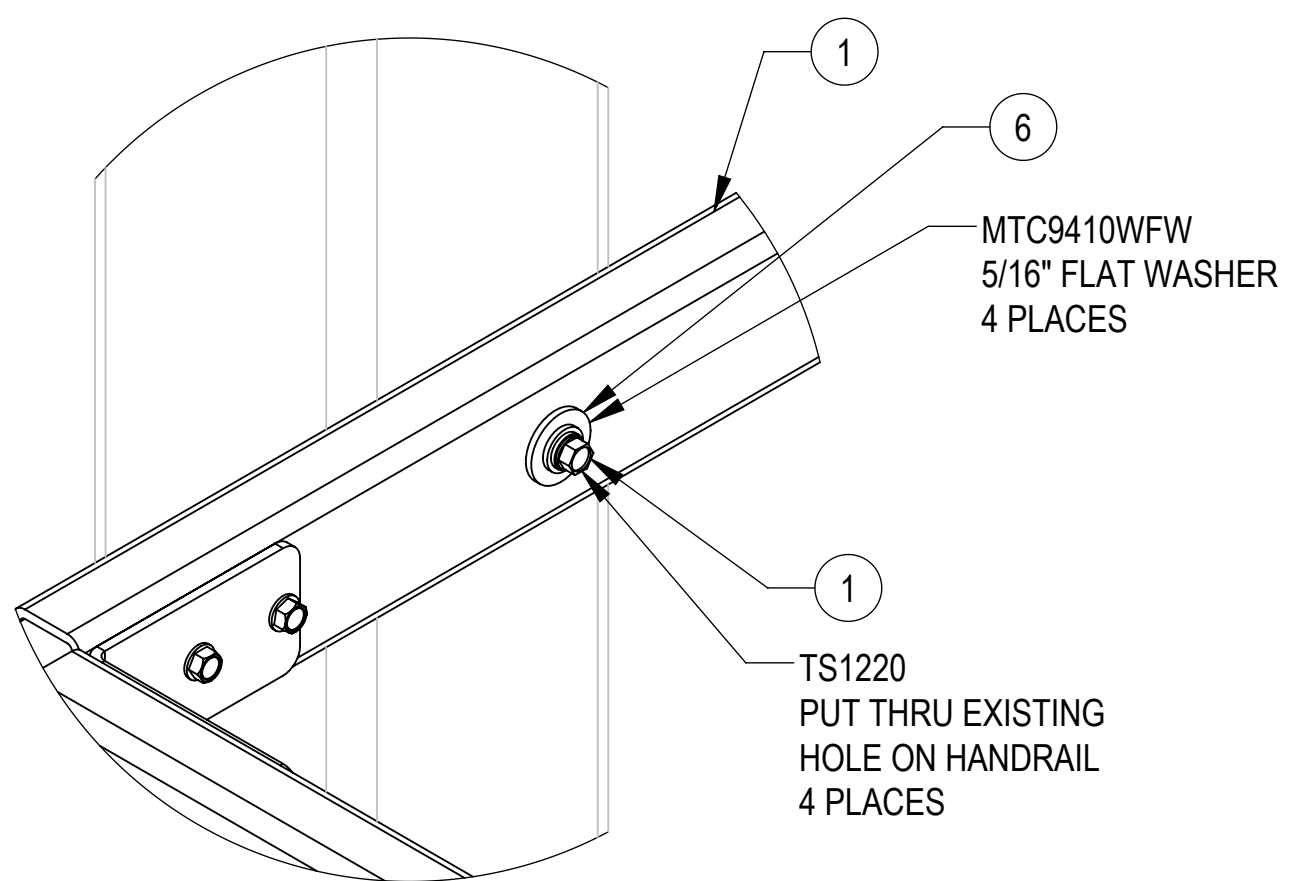

**DETAIL J**  
SCALE 1 : 2

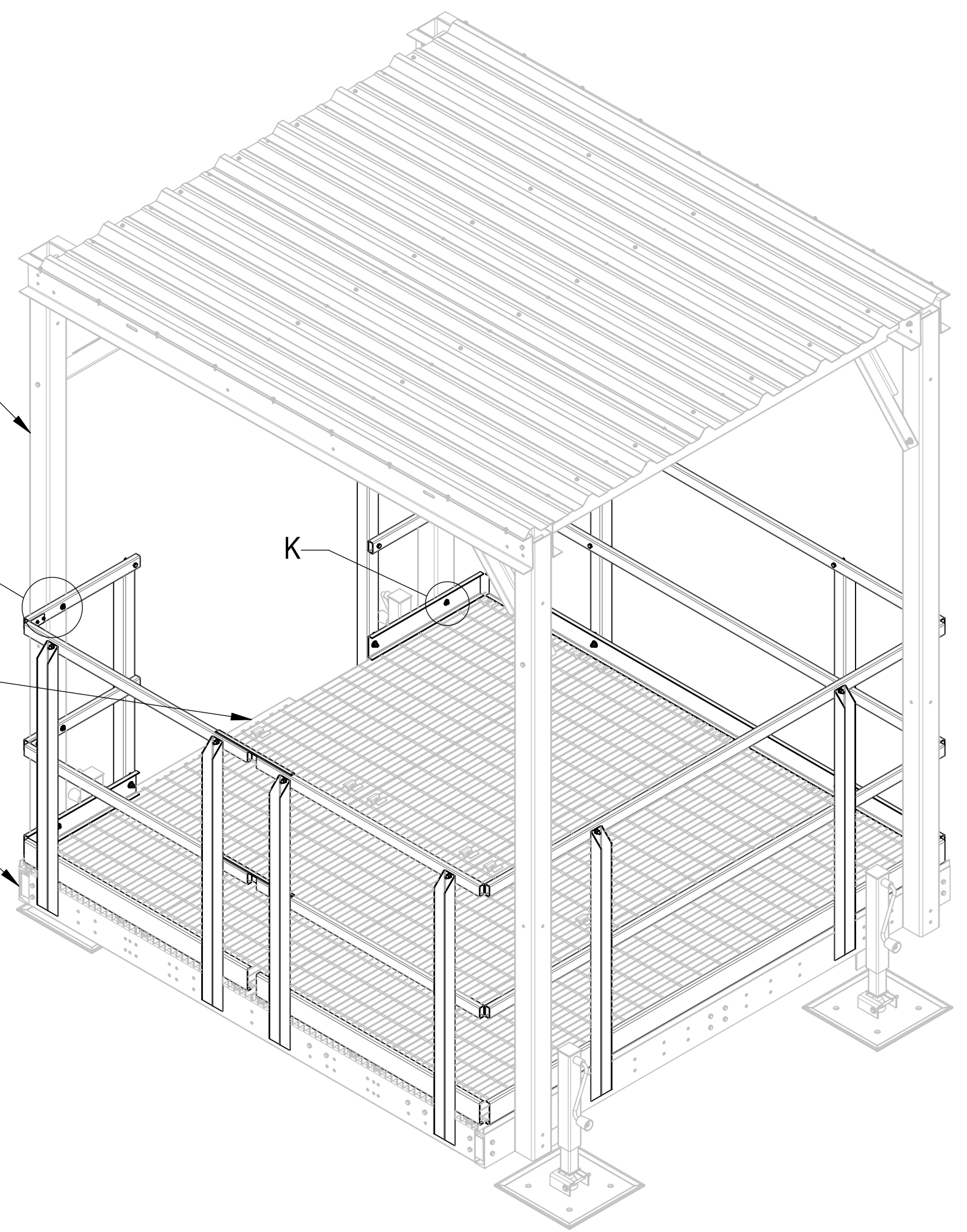

MTC4037CR  
SOLD SEPARATELY

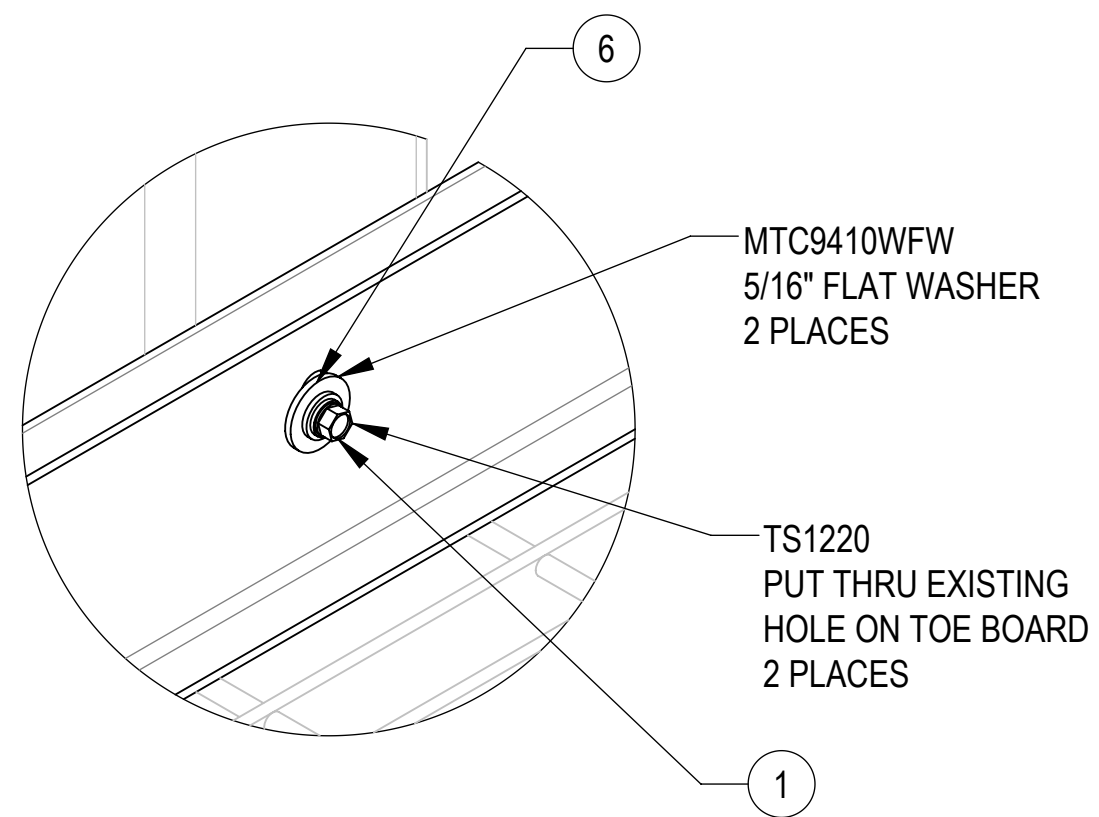

MTC4037AL AND MTC3922S36  
SOLD SEPARATELY

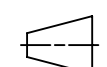

**DETAIL K**  
SCALE 1 : 2

 <b>ANDREW</b> an Amphenol company				
TITLE 8x8 PLATFORM HANDRAIL W TOE BOARD				
SIZE <b>C</b>	SCALE <b>1:16</b>	DOCUMENT NO. MTC4037HR		
 		DRAWING		SHEET 4 OF 6
		VERSION 05	STATUS RE	

Confidential

4

3

2

1

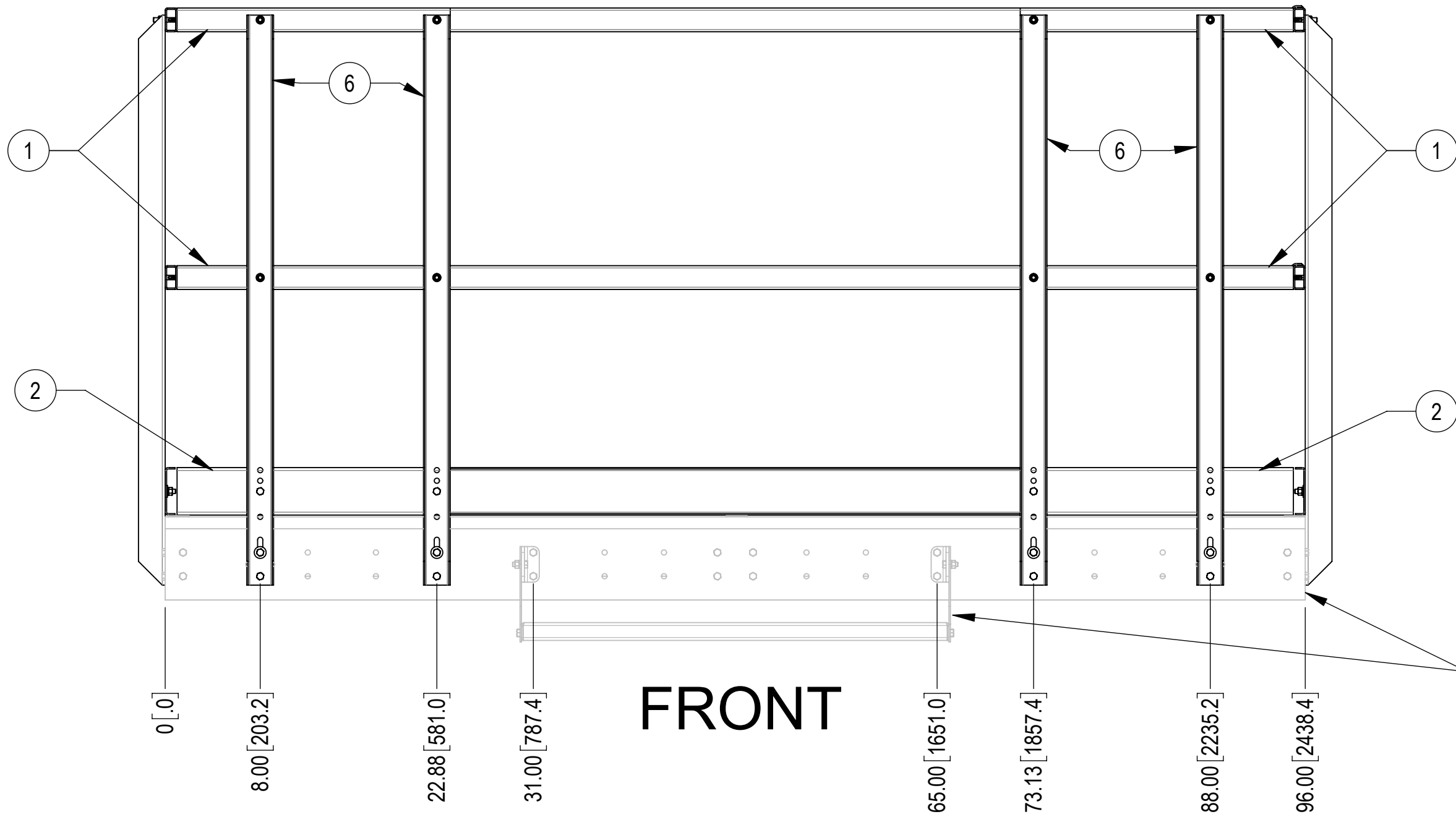

MTC4037AL AND MTC3922S36  
SOLD SEPARATELY

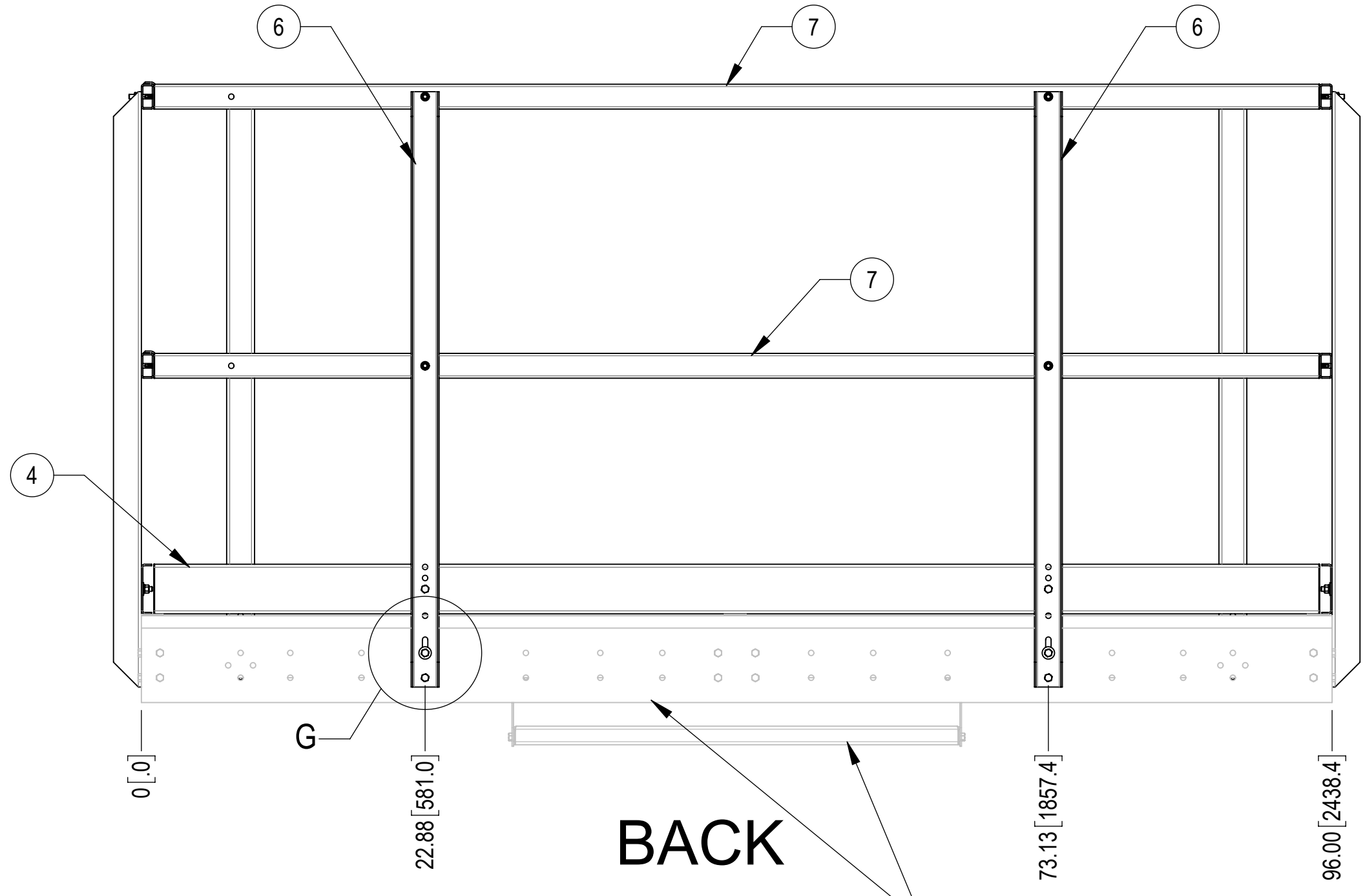

MTC4037AL AND MTC3922S36  
SOLD SEPARATELY

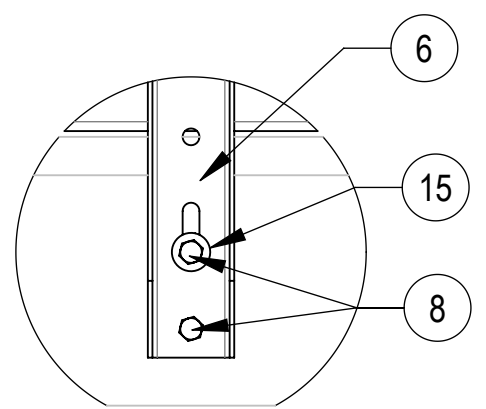

TYPICAL ALL  
HANDRAIL  
POSTS

**DETAIL G**  
SCALE 1 : 5

				
TITLE				
8x8 PLATFORM HANDRAIL W TOE BOARD				
SIZE	SCALE	DOCUMENT NO.		
<b>C</b>	<b>1:10</b>	MTC4037HR		
		DRAWING		SHEET
		VERSION	STATUS	REVISION
		05	RE	E
				SHEET 5 OF 6

Confidential

HAND RAIL & STEP CAN BE MOUNTED TO EITHER SIDE

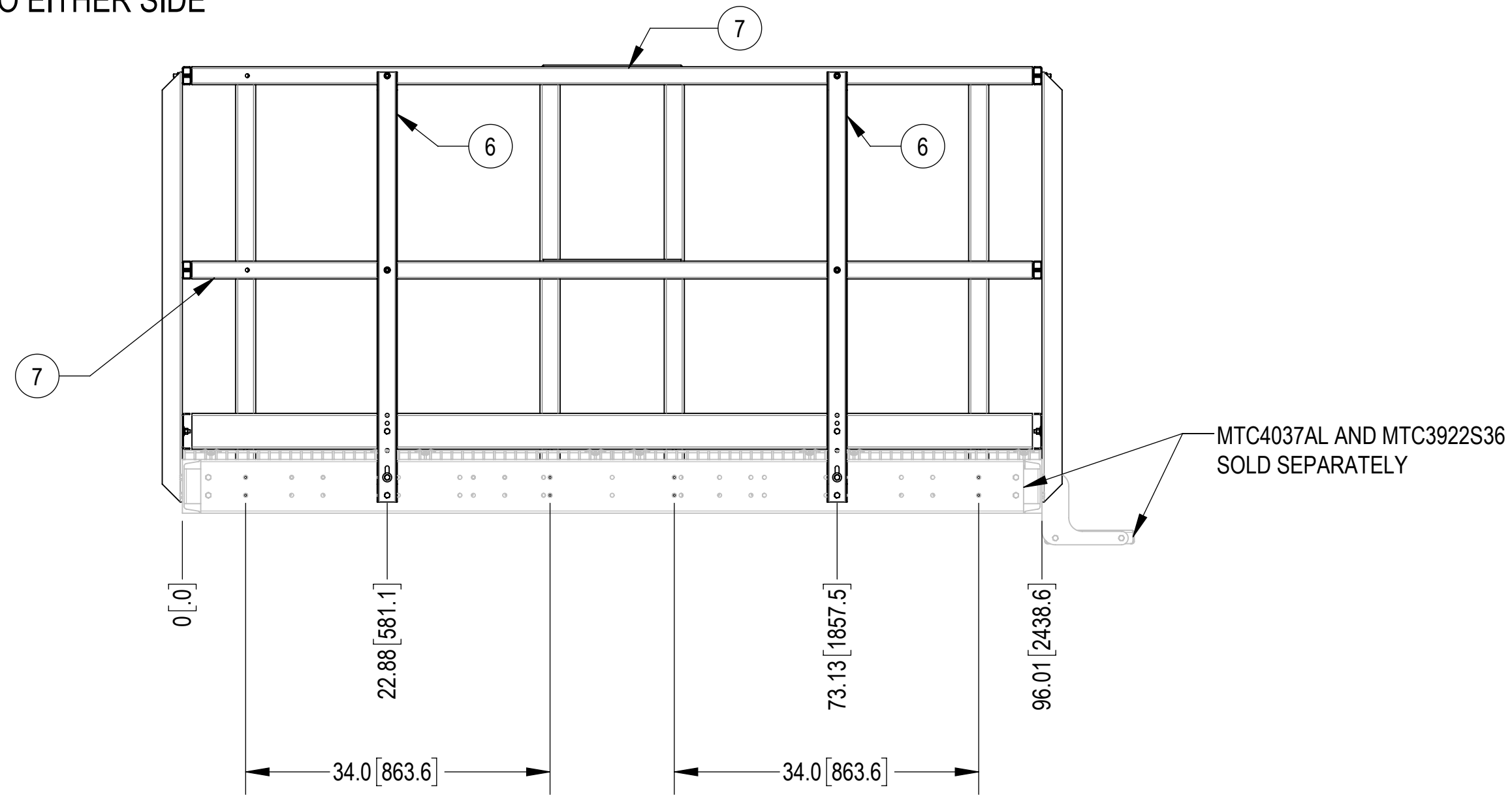

LEFT SIDE

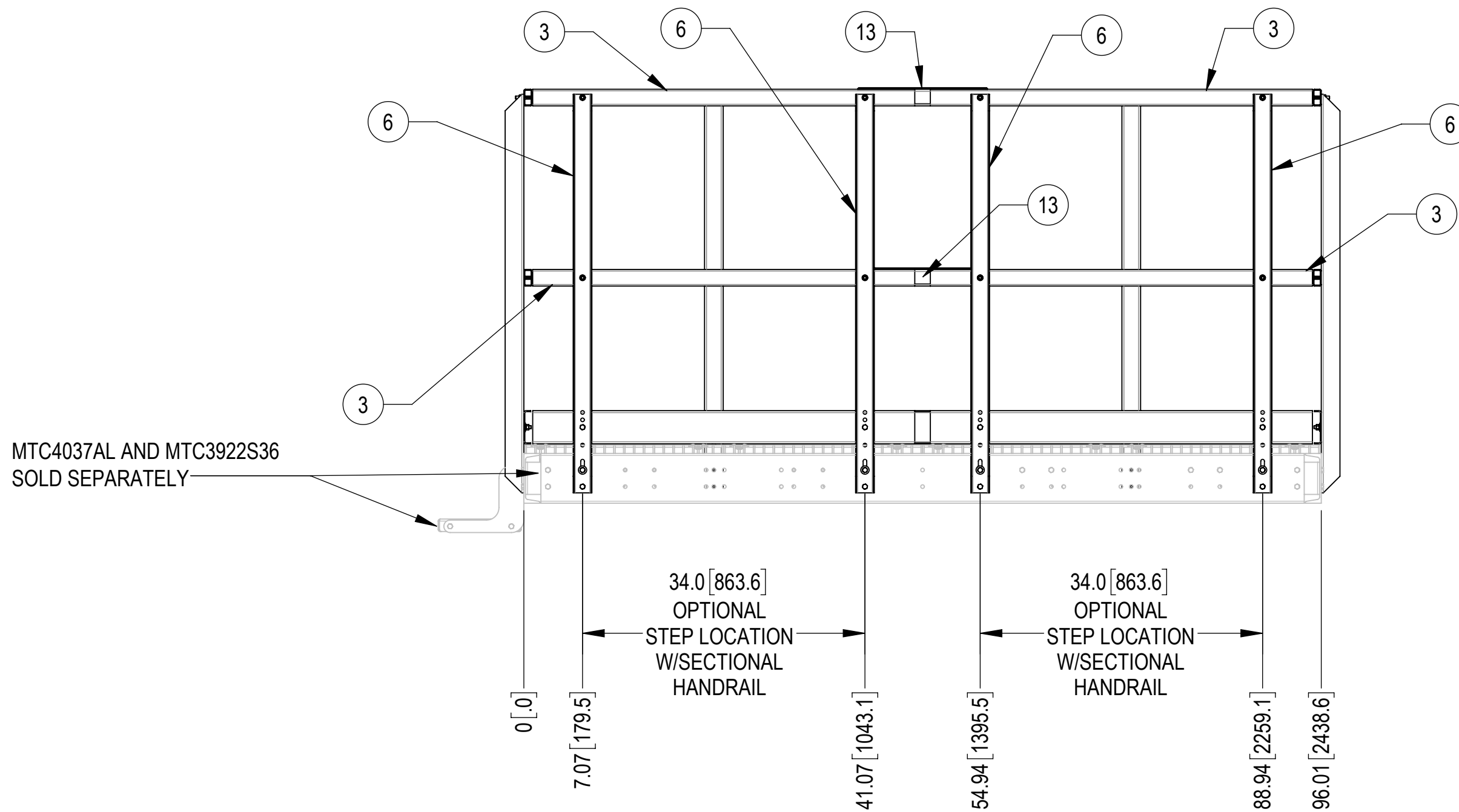

RIGHT SIDE

**ANDREW** an Amphenol company

TITLE  
8x8 PLATFORM HANDRAIL W TOE BOARD

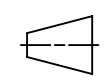
SIZE <b>C</b>	SCALE <b>1:14</b>	DOCUMENT NO. MTC4037HR		
 		DRAWING		SHEET
		VERSION 05	STATUS RE	REVISION E

Confidential